

## Liquid Cooled Technology



# CPLC

Cold plate liquid cooled heater/cooler

# Thermoshake AC LC

Heating, cooling and shaking in one liquid cooled device



# Liquid Cooled Technology

Inheco's liquid-cooled devices replace the usual on-deck heat sink/fan combination with liquid heat exchangers and transfer heat to the environment via a heat exchanger outside the deck. For assays that require high precision there's less risk of disturbance or contamination from waste heat generation or air movement from fans.

**On-deck liquid cooled device**

**Off-deck heat exchanger**

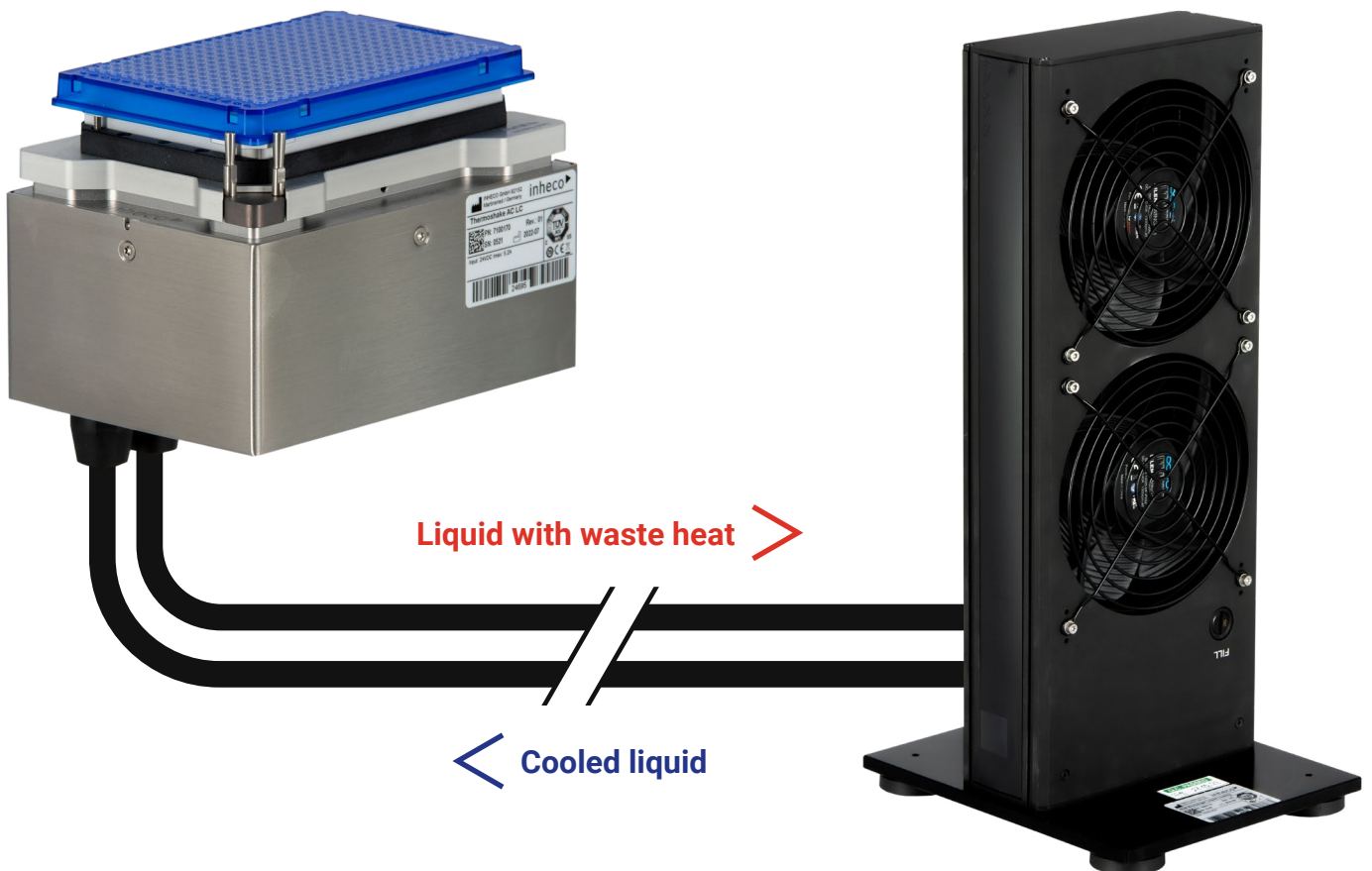

# CPLC

## Cold plate liquid cooled heater/cooler



### Heat, cool or freeze your samples, not your deck!

Heat and cool samples precisely, without fear of contamination. Our Peltier-based heater/cooler uses liquid cooling for near-silent operation without generating waste heat or air on deck.

Labs report problems with on-deck waste heat that increases the ambient temperature of the deck, air movement from fans increases the risk of sample cross-contamination, and there's excessive noise when many devices work together. Cold plate liquid cooling moves heat dispersal off deck and can solve those problems.

### On-deck accurate heating and cooling

The CPLC uses a two Peltier heating/cooling capability. In a multi-unit setup, the Peltiers enable individual heating/cooling settings using just the one heat exchanger. The heat exchanger can be a passive ambient temperature unit, or an active cooler in case of very high/low temperature setting, including sub-zero. Temperature range 4°C to 110°C, uniformity of 0.5K, accuracy of 0.3K.

### Easy to integrate

The CPLC occupies only one ANSI/SLAS plate position on deck. It comes with an API ready to integrate with your automated liquid handling workstation. Control your CPLC with the separate off-deck Inheco Single TEC Control unit (STC) which further minimizes deck space and reduces noise and temperature. Or choose the Inheco Multi TEC Control unit to control up to six devices in parallel when using several Inheco products on your deck.

### Adaptable

You can use your preferred disposable with the CPLC, including vials and reservoirs – we offer over 200 adapters, manufactured in-house to ensure a perfect fit to the geometry of the disposable item, or can tailor an adapter to fit your needs.

## Application examples



# Applications

## Why use a liquid-cooled heater/cooler?

When your application needs cooling or heating surfaces, Peltier technology is often preferred. It offers heating and cooling plus temperature control all in one unit.

But if your units discharge waste heat or air on-deck they can cause excess heat or sample contamination, as well as noise. Moving heat exchange off-deck eliminates those problems.

## What to look for in a heater/cooler?

Accurate and uniform heating and cooling are important, as are the ability to maintain temperature precisely. Depending on your set-up, contamination risk and noise may also determine your choice.

- **Cooling capability** – Off-deck and liquid cooled or on-deck heat sink/fan combination
- **Temperature uniformity**  
Delivering identical temperature across the entire block, with identical results for samples in the middle or on the edge of the block, and throughout the run
- **Temperature accuracy** – Ensuring accurate and stable, reproduceable temperatures for the duration of the run, and for every sample in the block
- **Uniform temperature change (ramp rates)**  
Maintaining temperature uniformity across the entire block
- **Temperature range** – Maximum and minimum temperature offered, including the option for sub-zero temperatures
- **Small footprint** – Delivering the required performance while taking up as little space on deck as possible
- **Low profile** – To make pipetting and use of taller disposables easier

# Technology

## Heating and cooling

The CPLC heats and cools using a Peltier unit and prevents self-heating, enabling accurate incubation at ambient conditions. Peltier Modules or Thermoelectric Coolers (TECs) use the Peltier effect to create a heat flux between the junction of two different types of materials. A Peltier module is a solid-state active heat pump which transfers heat from one side of the device to the other side against the temperature gradient (from cold to hot), with consumption of electrical energy.

TECs run with DC voltage, and it's easy to control the heat transfer through the module by changing the current. When the polarity of the DC is switched, the TEC swaps from cooling to heating mode. That makes TECs an excellent solution when exact control of temperature and heating and cooling rates are needed.

## Liquid cooling

The CPLC uses an off-deck liquid heat exchanger to remove waste heat.

## Optional Heated Lid

- The Heated Lid can be used as an add-on heater on top of the CPLC, to increase the rate of heating, improve temperature uniformity (especially for deepwell plates), and enable longer incubation.
- The Heated Lid helps to avoid condensation at the top of the plate, and reduce losses due to evaporation, without needing the space of a dedicated incubator.
- The flexible cable and low weight (420g) mean it can be transported by most gripper systems, while being heavy enough to seal the plate, so allowing full automated processing.

## Software

**API available.** The Inheco CPLC is quick to connect, and ready for future developments in your lab.

# Technical data

## TECHNICAL DATA INCLUDING DIMENSIONS

CPLC type		Ultraflat 7100115	Ultraflat HT 2-TEC 7100117
Input voltage / max. current		12Vdc / 5.0A	24Vdc / 4.08A
Temperature range		+4°C to +70°C [+39.2°F to +158°F]	+4°C to + 105°C [+39.2°F to +221°F]
Temperature cycling		No	Yes
Max. reachable temperature difference	Heating mode	Up to 66K	Up to 80K
	Cooling mode	Up to 22K	Up to 30K
Sensor type		two PT100	
Inlet and outlet hose connection in mm		Outer diameter 8; inner diameter 6	Outer diameter 12.7; inner diameter 7.6
Outer dimensions for length x width in mm		128.9 x 89.1	
Outer dimensions for height in mm		53.3	66.1
Weight incl. cord		Approx. 0.73kg [1.61 lbs]	Approx. 1.10kg [2.43 lbs]
Noise		0dB(A) (max)	

## ENVIRONMENTAL CONDITIONS

Tolerable relative humidity	Operation	30-80% relative (non-condensing*)
	Transportation and storage	10-80% relative (non-condensing)
Temperature	Operation	+15°C to +32°C [+59°F to +90°F]
	Transportation and storage	-20°C to +60°C [-4°F to +140°F] (non-condensing)

\*Condensate can prevent the CPLC from operating properly and can damage the CPLC. Condensate should be eliminated on a daily basis or more often, for example by heating cycles in between cooling cycles.

### Ultraflat HT 2-TEC

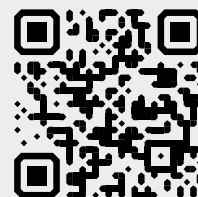
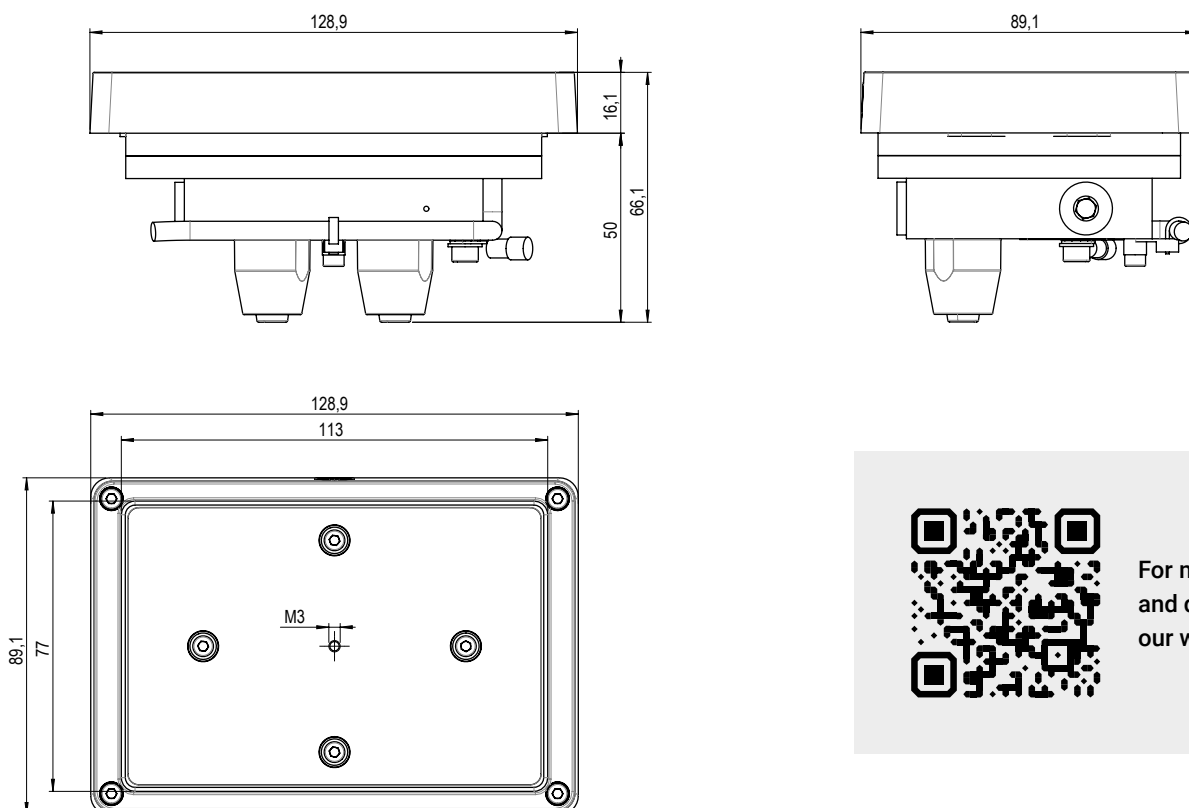

For more information and downloads visit our website

# Thermoshake AC LC

Heating, cooling and shaking with active clamping and liquid cooling



## Precise heating, cooling & shaking in one small device!

Combined heater/coolers and shakers can be problematic when working without on-deck air-conditioning. Labs report problems with on-deck waste heat that increases the ambient temperature of the deck, air movement from fans increases the risk of sample cross-contamination, and there's excessive noise when many devices work together. Liquid cooling moves heat dispersal off deck and can solve those problems.

Save precious deck space with one device that delivers accurate heating, cooling and rapid shaking of up to 500g loads with rapid shaking at up to 3000rpm thanks to its automated clamping technology.

Combined heater/coolers and shakers add efficiency and precision to liquid handling decks for many life science research applications in molecular biology, biochemistry and clinical chemistry. They give labs more control of the process, and that helps achieve more accurate and repeatable results. And by reducing reaction process times and lessening operator workload they can help increase lab throughput.

## Uniformity and accuracy

The Thermoshake AC LC gives you precise control over sample processing. Define set temperatures with a temperature range of 4°C to 70°C and a uniformity and accuracy of 0.3K. Choose the orbital shaking frequency, from 300 to 3000rpm. For every temperature and every frequency, you'll get uniform and accurate processing for every sample.

## Easy to integrate

The Thermoshake AC LC has a small footprint, zero positioning function for comfortable robotic gripping, and it's integrated with all major deck manufacturers enabling immediate plug-and-play. API available.

## Adaptable

Use your preferred disposable with the Thermoshake AC LC active clamping (automated labware clamping), using customized clamping rods for different labware, lets you use different format plates without adjustment. That also enables you to shake plates with clamped lids and allows piercing through sealing foils while keeping the plate firmly clamped. We offer over 200 adapters, manufactured in-house to ensure a perfect fit to the geometry of the disposable item, or can tailor an adapter to fit your needs.



## Application examples



# Applications

## Why use a combined thermoshaker?

Heating, cooling and maintaining ambient temperatures, while shaking, are fundamental to many life sciences processes carried out in an automated liquid handling deck. When on deck space is at a premium, it makes sense to use one multi-functional combined device – but only when you can be sure performance won't be compromised.

## What to look for in a combined thermoshaker?

Accurate uniform heating, cooling and shaking for every sample are the prerequisites for thermoshakers. That means ensuring that your samples are safely clamped during the shaking, and that they all reach the same temperature for the same amount of time.

- **Temperature uniformity** – Delivering identical temperature across the entire block, with identical results for samples in the middle or on the edge of the block, and throughout the run
- **Temperature accuracy** – Ensuring accurate and stable, reproduceable temperatures for the duration of the run, and for every sample in the block
- **Uniform temperature change (ramp rates)** – Maintaining temperature uniformity across the entire block
- **Shaking options** – Both speed and pattern (for linear shaking, see our Thermoshake Classic)
- **Load** – Handling the heaviest load you are likely to require
- **Automated clamping technology** – Secure grip on disposable while shaking
- **Small footprint** – Delivering the required performance while taking up as little space on deck as possible

## Use of the Thermoshake AC LC

- The Thermoshake AC LC is in regular use in NGS Sample Prep.
- In bead extraction, when lysis is performed with higher temperature and the next steps require RT processing. The Thermoshake AC LC's higher shaking with higher load allows magnetic bead extraction of "heavy bead" even in larger disposables.
- The Thermoshake AC LC can also be used to keep samples at room temperature during shaking.

# Technology

## Shaking

- The Thermoshake AC LC shakes using an electromagnetic motor
- Orbital shaking pattern
- 300-3000rpm
- 2mm amplitude
- Anti-spillage
- Anti-vibration

## Heating and cooling

The Thermoshake AC LC heats and cools using a Peltier unit and prevents self-heating at ambient incubation to allow the cooling function to operate.

- Peltier Modules or Thermoelectric Coolers (TECs) use the Peltier effect to create a heat flux between the junction of two different types of materials. A Peltier cooler, heater, or thermoelectric heat pump is a solid-state active heat pump which transfers heat from one side of the device to the other side against the temperature gradient (from cold to hot), with consumption of electrical energy. TECs run with DC voltage, and it's easy to control the heat transfer through the module by changing the current. When the polarity of the DC is switched, the TEC swaps from cooling to heating mode. That makes TECs an excellent solution when exact control of temperature and heating and cooling rates are needed.
- Temperature range: +4°C to +70°C
- From 20°C to 68°C in 300sec, or 9°C per minute heating rate (to ensure precise temperatures)
- From 70°C to 25°C in 450sec, or 6°C per minute cooling down
- Optimized temperature control to avoid overshooting or undershooting of target temperature

## Liquid cooling

The Thermoshake AC LC uses an off-deck liquid heat exchanger to remove waste heat.

## Software

**API available.** The Inheco Thermoshake AC LC is quick to connect, and ready for future developments in your lab.

# Technical data

## TECHNICAL DATA INCLUDING DIMENSIONS

<b>Product number</b>	7100170
<b>Height (bottom to contact surface)</b>	90.6mm [3.567in]
<b>Height with standard fixation pins</b>	96.9mm [3.814in]
<b>Length x width</b>	147mm x 104mm [5.787in x 4.095in]
<b>Temperature range</b>	+4°C to +70°C [+39.2°F to +158°F]
<b>Maximum temperature difference in cooling mode</b> $\Delta T (= T_{\text{ambient}} - T_{\text{target}})$	25K
<b>Noise</b>	Max. 42dB(A)
<b>Protection category</b>	IP 20
<b>Weight including cables</b>	3.8kg [8.4lbs]

## TECHNICAL INFORMATION REGARDING SHAKING FOR ALL DEVICES

<b>Maximum load</b>	1.0kg [2.2lbs]
<b>Shaker frequency (Weight reduces the max. speed)</b>	300 to 3000rpm*
<b>Shaking amplitude</b>	2mm [0.07874in]
<b>Shaking pattern</b>	Orbital

\* Depending on the load, as otherwise liquid might get spilled or adapter might not be hold tight to the clamp mechanism. We recommend to test the speed you want to use with a microtiter plate and water to test the behavior first.

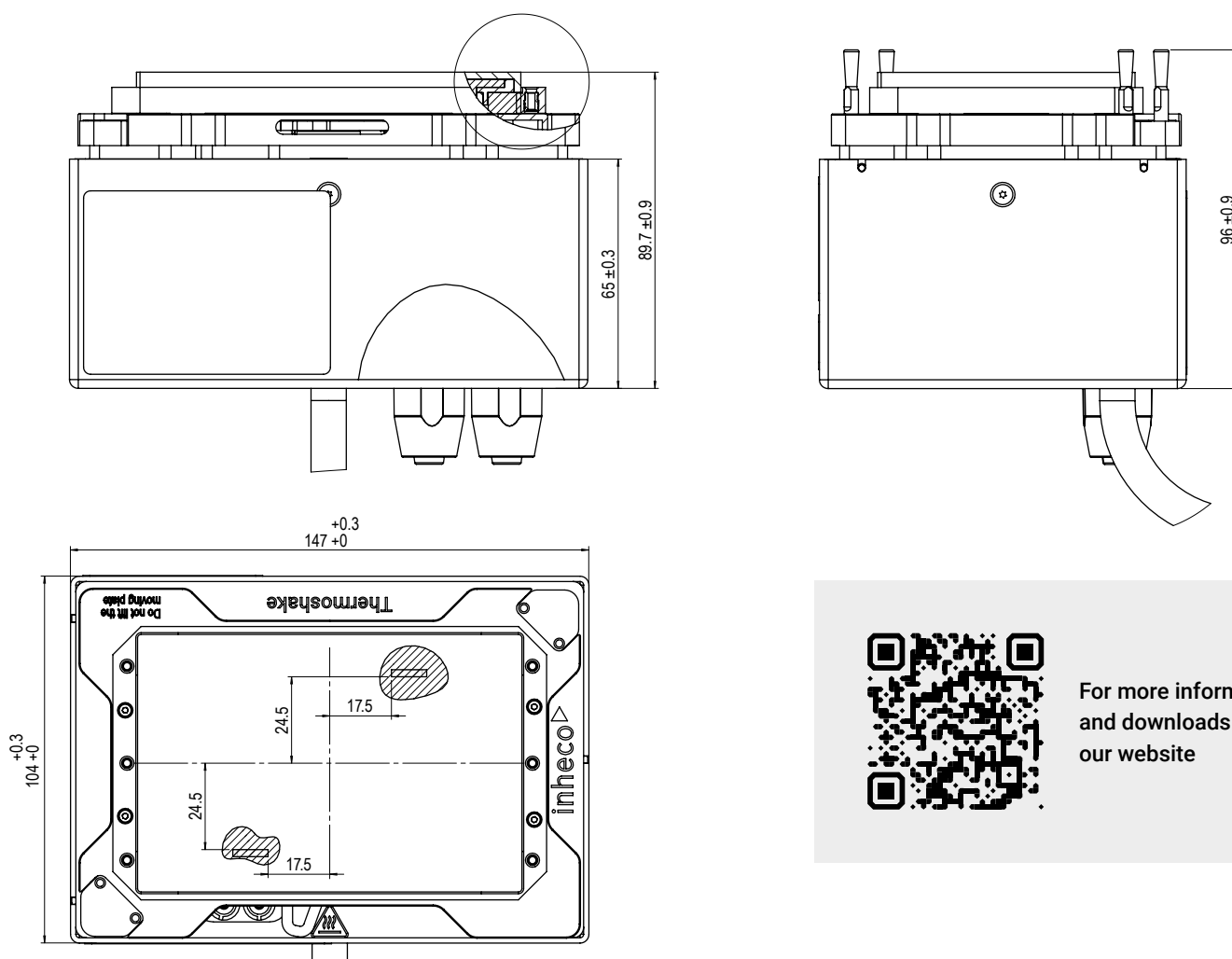

For more information and downloads visit our website

# About Inheco

## **Market-leading, Customer-led devices for automated liquid handling platforms**

We've been designing, making and supplying devices for automated liquid handling platforms for more than 20 years. Our customers include major manufacturers, integrators and end-users in big pharma, biotech, diagnostics and research & academia. We develop our products based on our customer needs, market knowledge and innovative strength.

## **Reliable and supported**

Every Inheco device is designed, engineered and made in Germany and undergoes rigorous quality control before delivery. It comes with a global two-year warranty and full customer service including remote support, diagnostic and servicing options that focusses on minimizing operational downtime.



Inheco GmbH  
Fraunhoferstrasse 11  
82152 Martinsried / Germany

## **Contact us**

Phone +49 89 89 95 93 -120  
E-Mail [sales@inheco.com](mailto:sales@inheco.com)

[www.inheco.com](http://www.inheco.com)